

# TOOL

## ASSEMBLY INSTRUCTIONS: Assembly Tool Kits for Band Type Segmented Socket Fittings FF759 and 1607

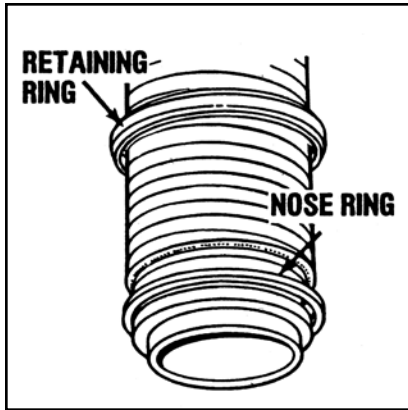

**Step 1.**  
Slip the flat retaining ring on the hose. Place the nose ring over the nipple and insert the nipple into the hose until it bottoms on the nipple shoulder.

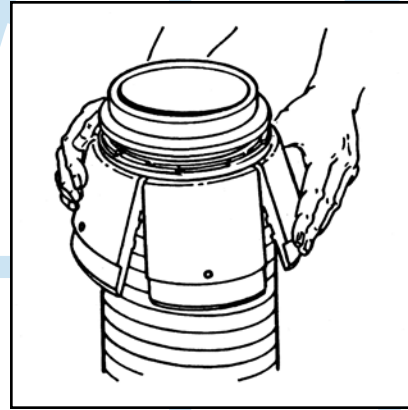

**Step 2.**  
Hook the segments under the nose ring and space them evenly around the hose.

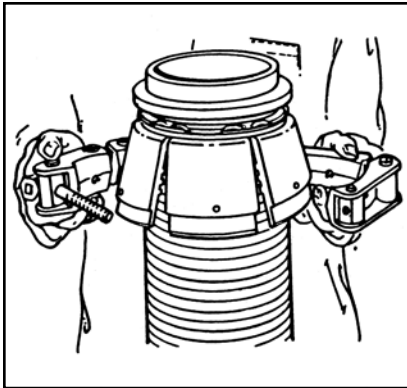

**Step 3.**  
Open the assembly tool and attach it over the segments by inserting the locating pins into the hole in each segment. Adapter pads are required when assembling 2 1/2", 4" and 6" sizes. Although the FF759 Kit is a 4 segment tool, the assembly procedures are the same as the 1607 Kit.

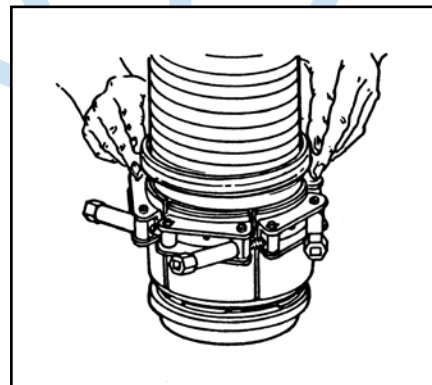

**Step 4.**  
Wrench tighten the assembly tool sections uniformly around the fitting. Slide the retaining ring over the compressed segments. Loosen the assembly tool and remove. Use the reverse procedure to remove fittings from hose.



Underway Replenishment Systems  
Navy Standard Valves  
Fluid Control Systems

Telephone: 814-445-9671 • FAX: 814-443-1453  
www.globalsfc.com • www.unrep.us